



WRITTEN DESCRIPTION REQUIREMENT AND SECTION 112(F)

DALE LAZAR

ANTONIN SCALIA LAW SCHOOL
GEORGE MASON UNIVERSITY

MARCH 23, 2021

703-855-3208
LAZARPATENTS@GMAIL.COM

1



EXAMINING COMPUTER-IMPLEMENTED FUNCTIONAL CLAIM LIMITATIONS FOR COMPLIANCE WITH SECTION 112 – PUBLISHED JANUARY 7, 2019 (84 FED. REG. 57-63)

Section 112(f)(means-plus-function)

- If a claim element uses the word “means,” there is a presumption that the applicant intends to invoke Section 112(f)
 - If a claim element does not use the word “means,” there is a presumption that the applicant does not intend to invoke Section 112(f)
 - BUT the presumption can be overcome in both directions
- 

2

EXAMINING COMPUTER-IMPLEMENTED FUNCTIONAL
CLAIM LIMITATIONS FOR COMPLIANCE WITH
SECTION 112 – PUBLISHED JANUARY 7, 2019 (84 FED. REG. 57-63)

Section 112(f)(means-plus-function)

- A claim element with the word “means” will not be interpreted under Section 112(f) if the element does not recite a function or if the claim element recites a function, but also recites sufficient structure to perform the recited function
- A claim element without the word “means” will be interpreted under Section 112(f) if the claim language is not sufficiently structural
- Standard for avoiding Section 112(f): Are the words of the claim understood by persons of ordinary skill in the art to have a sufficiently definite meaning as the name for structure or the claim recites sufficient structure for performing the recited function

3

YORK PRODUCTS V. CENTRAL TRACTOR

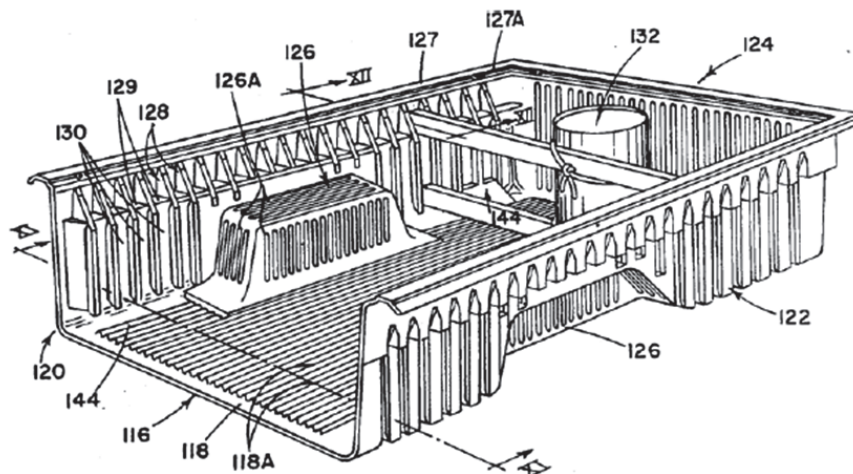

FIG. 7

4

YORK PRODUCTS V. CENTRAL TRACTOR

32. A protective liner for a cargo bed of a vehicle, said protective liner allowing a structure positioned in the truck cargo bed to be supported and affixed in position in the vehicle cargo bed, including:

a liner floor portion having elevated portions formed thereupon to conform to wheel wells protruding from the cargo bed floor;

upwardly extending liner sidewall portions extending upwardly from opposite sides of the liner floor portion;

an upwardly extending liner frontwall portion extending upwardly from a front end of the liner floor portion; and

means formed on the upwardly extending liner sidewall portions including a plurality of spaced apart, vertically extending ridge members protruding from the liner sidewall portions and forming load locks in gaps separating adjacent ones of the ridge members, said load locks having a depth sufficient to anchor a structure positioned and supported in the cargo bed.

5

COLE V. KIMBERLY-CLARK

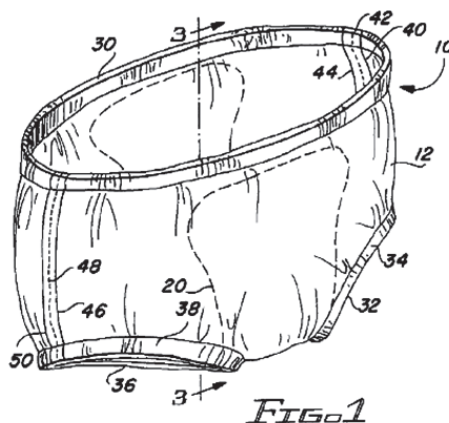

6

Find the full text of this and thousands of other resources from leading experts in dozens of legal practice areas in the [UT Law CLE eLibrary \(utcle.org/elibrary\)](https://utcle.org/elibrary)

Title search: Written Description Requirements and Section 112(f)

Also available as part of the eCourse

[2021 Advanced Patent Law \(USPTO\) eConference](#)

First appeared as part of the conference materials for the
16th Annual Advanced Patent Law Institute session

"Written Description Requirements and Section 112(f)"